

TRIMMASTER

EMX-3
Electronic Metering Device
for Spot Gathering

INSTALLATION

and

OPERATING INSTRUCTIONS

TrimMaster
4860 North 5th Street Hwy.
Temple, PA 19560 USA

Telephone: (610) 921-0203
Fax: (610) 929-8833
E-mail: trim@trimmaster.com

TRIMMASTER

4860 North 5th Street Highway
Temple, PA 19560-1498 USA

Telephone (610) 921-0203
Fax (610) 929-8833
E-Mail trim@trimmaster.com

Dear Customer,

TrimMaster is pleased that you have selected our EMX-3 electronic metering device. When installed and connected properly, your unit should give you years of reliable service. Please read through the entire installation instructions before connecting or using your unit.

Please retain the carton in which the control box was shipped. This will ensure proper packaging should a return for service become necessary.

If, after reading these instructions and installing your unit, you have any questions, please call for assistance on our toll free line 1-800-356-4237.

Again, thank you for your purchase.

TrimMaster

CONTENTS

OVERVIEW.....	1
COMPONENTS.....	1
INSTALLATION.....	2
SYSTEM CHECK.....	4
OPERATING BASICS.....	5
CONTROL PANEL DISPLAY.....	6
CONTROL PANEL BUTTONS.....	8
BACK PANEL.....	10
PROGRAMMING.....	11
OPERATING THE EMX-3.....	12
APPENDIX A - SAMPLE TENSION SETTINGS.....	14
APPENDIX B - TROUBLE SHOOTING CHECKLIST.....	15
APPENDIX C - EMX-3 WORKSHEET.....	17

OVERVIEW

The TrimMaster Model EMX-3 is an electronic metering device that provides automatic spot gathering on practically any sewing machine. Using a small, fast microprocessor, it has features available in no other metering device.

The EMX-3 control box reads pulses generated by a synchronizer mounted on the sewing machine handwheel. These pulses are processed by the EMX-3 to control the stepper motor in the metering device mechanism. By using these pulses, the EMX-3 guarantees that the rollers in the metering mechanism precisely follow the motion of the sewing machine, no matter what the sewing machine speed is.

Other electronic metering devices depend on time to control transition from one tension to another. They require the machine to run at the same speed every time for seams to be consistent from one piece to the next. The EMX-3 does not depend on time or machine speed in any way for tension transitions. The metering device fast advances or pulls back during a transition consistently no matter how fast the sewing machine is going.

Often, sewing machines produce slightly longer stitches when they operate at high speeds than they produce at low speeds. Therefore, the EMX series of metering devices features sewing machine speed compensation. Without speed compensation, metering devices tend to feed either too much elastic at slow speeds or not enough at high speeds to maintain consistent gathering. When a compensation percentage is programmed into the EMX-3, the unit feeds elastic slightly more slowly at machine speeds below 1,200 RPM.

COMPONENTS

Your TrimMaster EMX-3 includes the following:

- Metering mechanism with motor and motor cord
- EMX Control Box
- Synchronizer
- Knee switch
- Power Cord
- Mounting Hardware
- Hardware for securing the Synchronizer.
- Installation and Operating Instruction manual
- Warranty Registration Form

TRIMMASTER

EMX-3 Installation and Operating Instructions

In addition, if your sewing machine requires the use of a handwheel adapter, it will be included (there is an additional charge for adapters). Certain Union Special and Rimoldi sewing machines require the use of a modified handwheel. In these cases a modified handwheel is included and a “core charge” is added to the invoice. Upon replacement of the handwheel, the old one can be returned for a full credit of the core charge.

INSTALLATION

Metering Mechanism and Control Box

- The following illustrations show three typical methods of mounting the EMX metering mechanism and control box. Mounting components are supplied based on the type of installation specified on your order for the EMX-3.

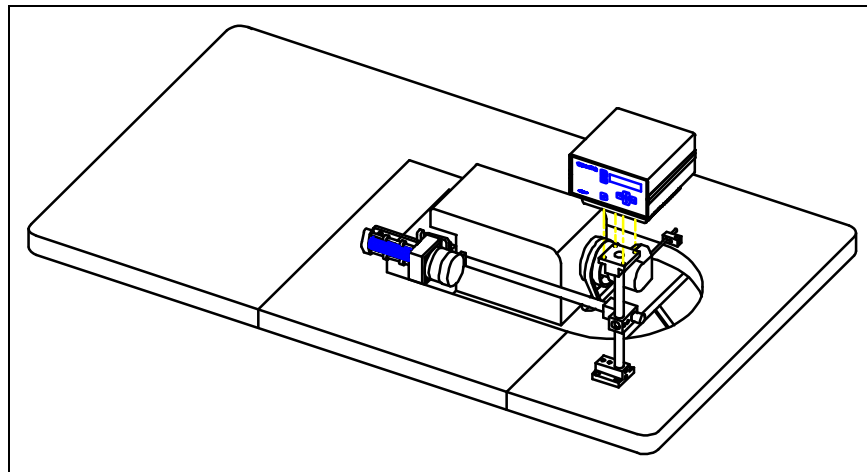

Top metering device on overlock machine

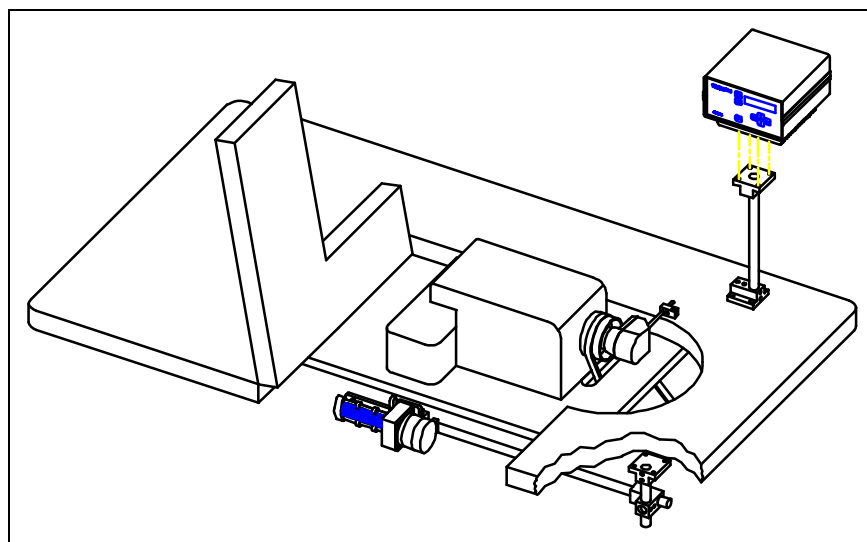

Bottom metering device on overlock machine

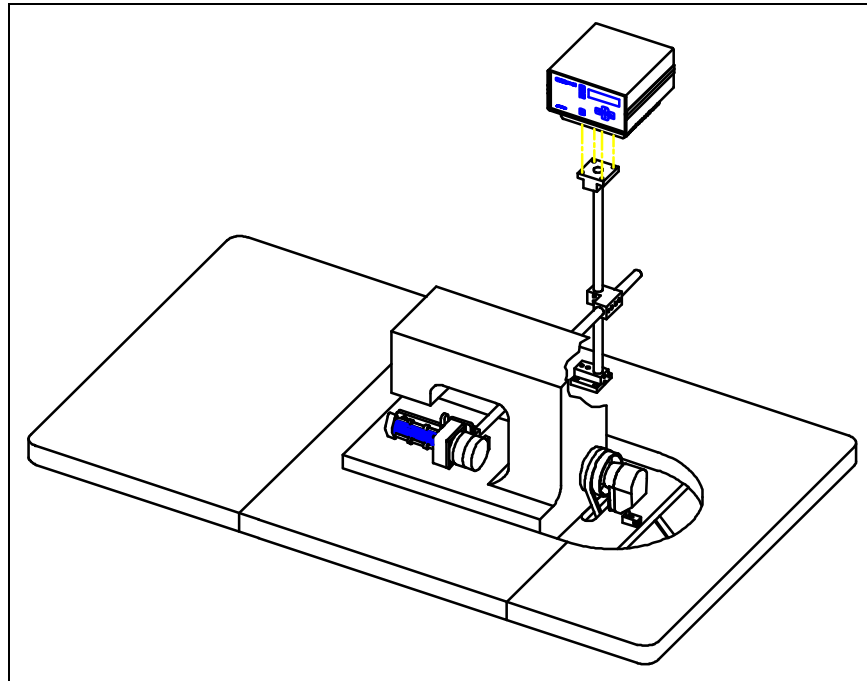

Top metering device on flatbed machine

Synchronizer

- As the above illustrations show, the synchronizer must be secured using the “L” shaped bar included with the mounting hardware. The synchronizer may be mounted at any angle, but it must be prevented from turning when the sewing machine is in motion. If your sewing machine is already equipped with a synchronizer, please contact TrimMaster for specific instructions before proceeding.
- The synchronizer cord is connected to the synchronizer input connector on the rear panel of the control box.
- **Note:** Power *must* be turned off to the control box when connecting or disconnecting any interface cords or the power cord.

Knee Switch

- The knee switch may be mounted anywhere on the sewing table where it is convenient for the operator. It is plugged into the EMX control box rear panel at the connector marked “KNEE”.

Power Cord

- The power cord provided must be wired into the switch box on the sewing machine stand. The proper voltage can be determined by checking the voltage requirement indicated on the rear panel of the control box.

EMX-3 Installation and Operating Instructions

!!!! WARNING !!!!

- A shock hazard exists when connecting into the switch box on your sewing machine stand. Be sure all power is removed before attempting to make the following connections.

!!!! WARNING !!!!

- **220 Volt, 3-Phase:** The white and black wires in the power cord must be connected to the two low legs between the switch and the sewing machine motor. This will ensure that when power is switched off to the sewing machine, it will also be switched off to the control box. The green wire must be connected to ground. Use the existing ground connection inside the switch box.
- **110 Volt, Single-Phase:** The power cord should be wired into your switch box (if the switch box allows for additional connections) or to the sewing machine motor terminal strip. The black wire should be connected to the live ("hot") supply line, the white to the neutral supply line, and the green to earth ground.

Motor Cord

- The end of the motor cord with the black boot is connected to the metering mechanism motor at the factory. Notice that the cord and connector are secured to the metering mechanism with three cable ties. It is important to replace these ties if the connection is disturbed. The connector on the end of the cord is not designed to withstand strain on the cord by itself.

If you do have to reconnect the motor cord, notice that the plug is keyed so that it can be fastened to the motor in only one way. The other end of the motor cord is connected to the motor connector on the rear panel of the control box.

- **Important:** When installing the EMX-3, secure the motor cord to the mounting hardware with cable ties. Be sure not to place any strain on the cord, and be sure to secure the cord out of the way of any moving parts.
- **Note:** The motor plug can be inserted into the control box in two ways to allow the motor to rotate in either direction. See System Check below.

SYSTEM CHECK

The following steps will ensure that your EMX-3 has been installed properly and will be ready for setting the system to your specific application:

- Disconnect the power cord from the EMX-3.
- Re-connect power that had been disconnected when wiring the power cord into the switch box.
- Turn on sewing machine motor switch to ensure connections in the switch box are correct.

EMX-3 Installation and Operating Instructions

- Turn off the sewing machine motor switch.
- Re-connect the EMX-3 power cord to the control box.
- Turn on the sewing machine motor switch.
- Turn on the EMX-3 power switch. The LCD screen should glow and the startup display should appear.
- Momentarily press the jog button on the front panel of the control box.. The metering rollers should rotate. Press the jog button again and insure that the rollers are rotating in the proper direction.

If the rollers are turning in the wrong direction turn off the power and disconnect the motor cord from the control box. Rotate the motor cord plug 180 degrees and re-insert it into the control box. Turn the power back on. Momentarily press the jog button to ensure the rollers are turning in the correct direction.

- With power still turned on, depress the sewing machine treadle to start the sewing machine. The metering rollers should rotate in the proper direction.

OPERATING BASICS

The EMX-3 stores three "setups", each with five "steps". A setup is a gathering pattern for a particular type of garment or a particular size.

The steps in a setup can, for example, produce a seam that starts out with elastic applied flat, then a section gathered tight, then a section gathered loose, then another tight, then flat again. At the beginning of each step, the EMX-3 can either fast-advance or pull back the elastic to produce a clean transition from one gathering rate to the next.

If you wish, any step can be controlled by a programmable stitch count. When the EMX-3 has sewn the desired number of stitches, it can automatically advance to the next step. Each step can be independently programmed to use or not use stitch counting. When stitch counting is not used, you can change steps using a knee switch or other convenient device.

The EMX-3 is always in one of two modes: "set mode" or "run mode". It must be in set mode to enter programmable settings, and it must be in run mode to actually operate (see Set/Run key description).

In run mode the EMX-3 maintains consistent elastic tension by metering at a calculated ratio to the sewing machine speed. The display identifies the setup and step and the current tension setting. The tension setting has no explicit meaning because the amount of stretch imparted to the elastic depends on both the EMX setting and stitch length. A formula for setting the tension is described in the following section, and sample settings are shown in Appendix A.

CONTROL PANEL DISPLAY

The TrimMaster EMX-3 front control panel looks like this:

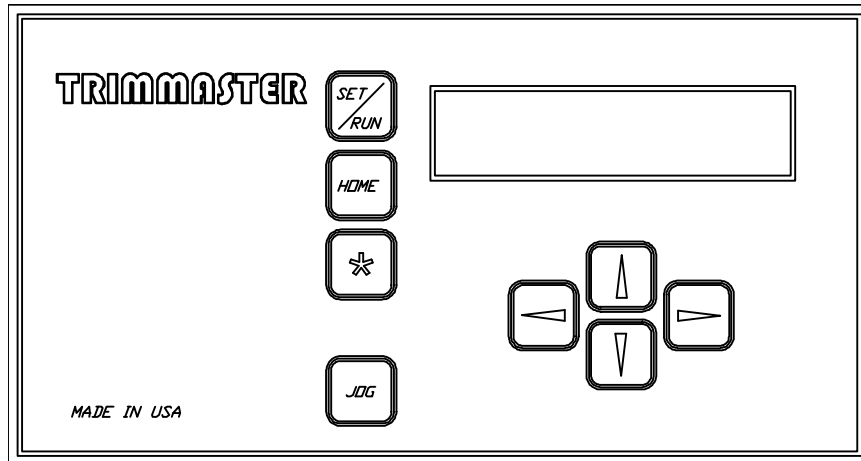

EMX front panel

The unit is controlled using the keys shown and the 2-line LCD (Liquid Crystal Display) screen in the upper right corner..

When the EMX-3 is first turned on, a screen like the following appears. The screen shows the software version number instead of "n.nn" as shown. Make a note of the software version number when calling the factory for assistance.

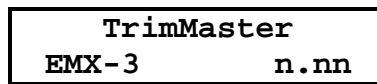

After approximately 3 seconds, the screen above is replaced by the following screen. This is how the display appears in run mode.

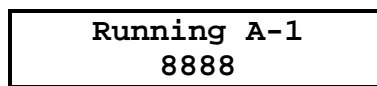

This is how the display appears in run mode. The "A-1" changes as the EMX-3 advances through the steps programmed by the operator. The "A" means "Setup A" and the "1" means "Step 1". The "8888" on the bottom line is replaced by the tension programmed for the setup and step shown.

Pressing the button marked "Set/Run" toggles the EMX-3 between run mode and set mode. Since the unit must be in run mode to operate, the EMX-3 starts up in run mode and automatically switches to run mode if the sewing machine starts to run. The sewing machine must be stopped and the EMX-3 put in set mode for the unit to be programmed.

EMX-3 Installation and Operating Instructions

In set mode, the screen shows the data relating to one step in one setup. The screen looks like this in "set mode":-

Set	Tnsn	AP	StCt
A-3	7500	10	0040

The four items displayed are:

Set Setup and step - In the example the setup is "A". It can be A, B, or C. In the example the step is 3. It can be 1, 2, 3, 4, or 5.

Tnsn Tension setting - This number controls how much the elastic is stretched when it is metered. The number has no direct meaning since the tension imparted to the elastic is a function of this setting **and** stitch length.

The table in Appendix A shows sample tension settings for various amounts of gathering and various stitch lengths. The formula for the tension setting is

$$\text{Tension} = 10511 - \frac{180.956 \times \text{stitches/inch} \times \text{stretched length}}{\text{gathered length}}$$

When setting tension, remember that a higher number makes the metering mechanism go faster - thus decreasing the tension:

Higher number -> faster -> less tension
Lower number -> slower -> more tension

AP Advance/Pull-Back - This setting controls the fast-advance or pull-back that precedes the change to the tension setting in the step displayed. The AP setting is the number of stitches over which the transition takes place.

If the step displayed represents a tighter tension than the one before it, the Advance/Pull-Back setting controls how far the elastic is pulled back as it changes to the new tension. This makes for a quick (rather than gradual) change to the new tension.

If the step displayed represents a looser tension than the one before, the Advance/Pull-Back setting controls how far the elastic is fast-advanced before changing to the new tension.

If this setting is set to 00, the EMX-3 does not fast-advance or pull-back. In this case the transition from one tension to another is gradual.

Setting Advance/Pull-Back is a matter of experience and trial and error. It is influenced by the distance between the metering rollers and the presser foot as well as the difference between the tension setting and the previous step's tension setting.

Note: Normally the tension in step 1 is the same as the tension in the last step used. A common use for spot gathering involves starting and ending a seam with the elastic sewn flat but gathered in the middle. In this case the AP setting has no effect, since the tension of one step (step 1) is the same as the preceding step (last step programmed). But, if the last tension setting is different than that in step 1, the AP setting is used, the transition is the same as between any two other settings.

StCt Stitch count - This number controls whether stitch counting is to be used and the number of stitches to count. Leave this number at 0000 if you wish to control changing to the next step using a knee switch.

Note: The knee switch can always override the stitch counter. Pushing the knee switch advances the EMX-3 to the next step and clears the internal stitch count.

One additional screen is available in set mode. It looks like this:

<p>Speed Adjustment > 0 Percent</p>
--

This screen appears when the setup is set below "A" (or above "C"). You can enter a speed adjustment percentage between 0 and 9. This percentage is used when the sewing machine is running below 1,200 RPM. It compensates for the sewing machine's tendency to generate slightly shorter stitches at low speed. To proceed with entering settings other than the speed adjustment, place the cursor under the ">" and press an up or down arrow.

The speed adjustment percentage can be set using trial and error, or it can be calculated. If you sew two pieces, one at low speed and one with the treadle fully depressed, you can count the stitches in equal lengths of each and use the formula:

$$\text{Percent} = \frac{(\text{Slow stitch count} - \text{Fast stitch count}) \times 100}{\text{Fast stitch count}}$$

CONTROL PANEL BUTTONS

The buttons on the control panel have the following functions:

Set/Run Pressing this button has an effect only when the sewing machine is stopped. Each press "toggles" between run mode and set mode. In other words, if the

EMX-3 Installation and Operating Instructions

EMX-3 is in run mode pressing Set/Run changes to set mode, and if the EMX-3 is in set mode pressing Set/Run changes to run mode.

You can tell you are in run mode when the screen looks like this:

```
Running A-1
       7500
```

In set mode the screen looks like this:

```
Set Tnsn AP StCt
A-3 7500 25 0040
```

Note: The EMX-3 must be in run mode to operate, so whenever the sewing machine is started with the EMX-3 in set mode, it automatically switches to run mode.

Home The Home button only has an effect in run mode. It simply sets the step back to 1. It is for situations where a work piece cannot be completed, and the EMX-3 needs to be set for the beginning of the next piece.

***** The “*” button is not used on the EMX-3.

Jog The Jog button works at any time. As the name implies, it jogs (runs) the motor in the metering mechanism for as long as the button is pressed.

Arrows In set mode the arrow keys control the information entered into the EMX-3. The left and right arrows move the underline cursor. The up and down arrows change the contents of a letter or number up or down.

Holding the arrow keys in causes the contents of a digit to keep changing as long as the key is held.

When the cursor is moved to its limit, either left or right, pressing the arrow again “wraps” the cursor around to the other extreme. Likewise, pressing the up or down arrow can “wrap” digits from 0 to 9 and 9 to 0.

In run mode only the up and down arrows are active, and then only when the sewing machine is stopped. They allow you to change the step number up or down without the EMX-3 fast advancing or pulling back. They allow you to resume work on a garment after a thread breaks or there is some other interruption.

BACK PANEL

The EMX-3 back panel looks like this:

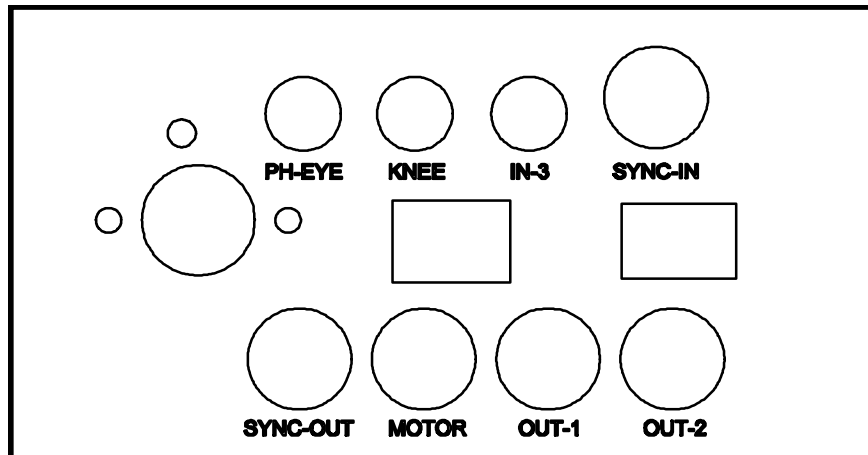

EMX back panel

The connectors on the back are for the following:

- PH-EYE** Photo-Eye - This connection is not used on the EMX-3.
- KNEE** Knee Switch - This is the plug for connecting the knee switch or other suitable device.
- IN-3** Input 3 - This connection is not used on the EMX-3.
- SYNC-IN** Synchronizer-In - This is the plug for the synchronizer supplied with the EMX-3.
- (Power)** The unlabeled black plug on the left center is for connecting power. The unit operates at 110 or 220 volts as indicated on the unit label.
- SYNC-OUT** Synchronizer-Out - This plug allows you to use the synchronizer to control other equipment in addition to the EMX-3.
- MOTOR** Motor - This plug is for connecting the motor in the metering mechanism.
- OUT-1** Output 1 - This connection is not used on the EMX-3.
- OUT-2** Output 2 - This connection is not used on the EMX-3.

Other items on the back are for the following:

- (Reset)** The small hole over the power connector provides access to a system reset switch. This reset should be used only if the unit is not operating at all or operating erratically. This may happen after long periods (months) of being

EMX-3 Installation and Operating Instructions

turned off. Use a ball point pen or other slender object to push in this switch momentarily. Resetting in this manner erases all user settings!

Fuse The main fuse is located inside the fuse holder. Gently press down and pull out the cover to gain access to fuses. One spare fuse is included inside the fuse holder. All fuses are 1/2 amp.

1/0 On/off switch.

The EMX-3 has unused inputs and outputs, because the same control box is used for various EMX series products. The microcontroller chip in the EMX-3 customizes the control box to operate as an EMX-3.

PROGRAMMING

The worksheet at the end of these instructions is recommended for organizing and documenting use of the EMX-3. There is room for a title at the top, and room for descriptions of steps beside each step's settings.

To program the EMX-3:

- Turn the power on.
- Wait for the run mode screen (approximately 3 seconds).
- Press the Set/Run key to put the EMX-3 in set mode.
- If programming a setup other than "A", press the left arrow key to position on the setup letter. Use the up and down arrows to select the setup to be programmed. Note that pressing the down arrow when "A" is showing causes the screen to change to the one for speed adjustment. Pressing an up or down arrow at the ">" position changes back to regular data entry.
- Using the left and right arrow keys, position on the step to be programmed (the step is the number after the dash under "Set"). Use the up and down arrows to set the step.
- Using the left and right arrow keys, position on each digit of the tension setting (under "Tnsn"). Use the up and down arrows to set each digit. Leave the tension setting at "0000" to indicate that the previous step was the last.
- Using the left and right arrow keys, position on each digit of the advance/pull-back setting (under "AP"). Use the up and down arrows to set each digit. Leaving advance/pull-back set to "00" causes the EMX-3 to skip any fast advance or pull-back when advancing to the tension showing.
- Using the left and right arrow keys, position on each digit of the stitch count setting (under "StCt"). Use the up and down arrows to set each digit. Note that leaving the stitch count at "0000" means that the operator will use a knee switch to advance from one step to the next.

EMX-3 Installation and Operating Instructions

- When all settings have been entered, either switch back to run mode by pressing the set/run button, or simply begin sewing. The EMX-3 automatically changes to run mode when the sewing machine begins to move. Whenever the EMX-3 changes from set mode to run mode, it automatically changes to step 1 of whatever setup is showing.
- At the end of the work day the EMX-3 can be switched off or power disconnected without affecting the settings programmed into the unit. The EMX-3's memory will last several months without power.

OPERATING THE EMX-3

Before starting on production goods, it is a good idea to become familiar with The operation of the unit controls. Have a small supply of scrap sample material available to test run the unit.

Route the elastic through the metering mechanism as shown below. It is not necessary to open the metering rolls to insert the elastic. Instead, bring the end of the elastic to the feed rollers and press the jog button on the front panel of the control box. The rollers will feed the elastic as long as the jog button is pressed.

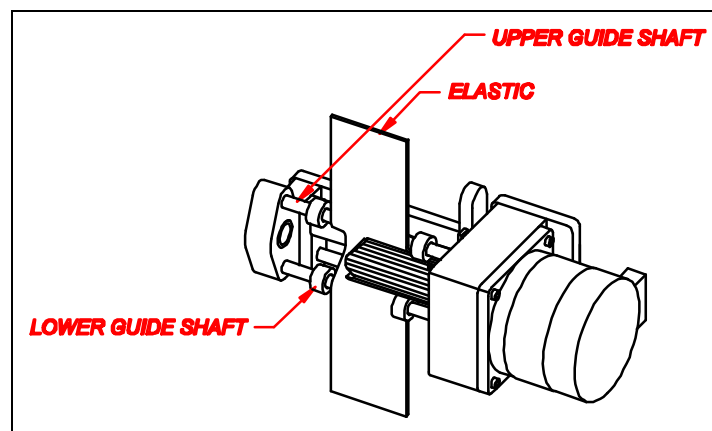

*Elastic threaded in metering mechanism
(cut-away view)*

The tension setting displayed on the front panel of the control box is set to 8888 when the EMX-3 is shipped from the factory and whenever the unit is reset using the reset button on the back of the control box. The 8888 setting is used to make it clear that the unit has probably been reset, it is not necessarily a typical setting.

A tension setting of 8000 is a good starting point for average tensioning of elastic. Sew a sample piece and note the amount of gathering obtained. Reset the tension setting to 8700. When making a tension setting change, it is necessary to sew out a couple of inches of elastic in order to transition to the new tension on the elastic. Now sew another sample piece and note the difference of tensioning on the elastic. You may wish to repeat

the above test with the tension setting set at 7300 to see the results obtained with a lower tension setting.

It is important to understand that if you wish the garment to finish larger than the previously obtained results, you must increase the tension setting. Conversely if you wish the garment to finish smaller than previously obtained, you must decrease the tension setting. It is also important to understand that if the garments to which you are attaching the elastic are not of equal length, then the finish measurement will also not be of equal length. Also, if you are using EMX-3 devices on other machines, the tension setting number will not necessarily yield exactly the same degree of gathering because the stitch lengths of the sewing machines are not set exactly the same.

We suggest you document desired settings on the EMX-3 Worksheet. You can store up to 5 steps in each of 3 setups and come back to them whenever returning to the same style garment. In most cases if pattern sizes are graded, a change in tension setting will not be necessary for changes in sizes.

It is not necessary or desirable to hold back on the garment when sewing. The tension setting will accurately feed the amount of elastic required.

As is the case with any machinery, if the machine will be unattended for any length of time, the power should be turned off. If the EMX-3 power cord has been wired into the sewing machine switch properly, power to the control box will also be turned off when the sewing machine is turned off. In this case it is not necessary to turn off the power on the EMX control box unless you wish to use the sewing machine without it.

APPENDIX A

Sample EMX Metering Device Tension Settings

Stretched/ Gathered	Stitches per Inch																
	4	5	6	7	8	9	10	11	12	13	14	15	16	17	18	19	20
1.00	9787	9606	9425	9244	9063	8882	8701	8520	8340	8159	7978	7797	7616	7435	7254	7073	6892
1.20	9642	9425	9208	8991	8774	8557	8340	8122	7905	7688	7471	7254	7037	6820	6602	6385	6168
1.40	9498	9244	8991	8738	8484	8231	7978	7724	7471	7218	6964	6711	6458	6204	5951	5698	5444
1.60	9353	9063	8774	8484	8195	7905	7616	7326	7037	6747	6458	6168	5879	5589	5299	5010	4720
1.80	9208	8882	8557	8231	7905	7580	7254	6928	6602	6277	5951	5625	5299	4974	4648	4322	3997
2.00	9063	8701	8340	7978	7616	7254	6892	6530	6168	5806	5444	5082	4720	4359	3997	3635	3273
2.20	8919	8520	8122	7724	7326	6928	6530	6132	5734	5336	4938	4539	4141	3743	3345	2947	2549
2.40	8774	8340	7905	7471	7037	6602	6168	5734	5299	4865	4431	3997	3562	3128	2694	2259	1825
2.60	8629	8159	7688	7218	6747	6277	5806	5336	4865	4395	3924	3454	2983	2513	2042	1572	1101
2.80	8484	7978	7471	6964	6458	5951	5444	4938	4431	3924	3418	2911	2404	1898	1391	884	377
3.00	8340	7797	7254	6711	6168	5625	5082	4539	3997	3454	2911	2368	1825	1282	739	197	

Notice to users of older style TrimMaster EMD metering devices: You can convert old EMD settings to new EMX tension settings using the following formula:

$$\text{New (EMX) tension setting} = 10,511 - \frac{2,560,000}{\text{Old (EMD) tension setting}}$$

APPENDIX B

Trouble Shooting Checklist

If you experience difficulty with your EMX-3, please use this checklist before calling the factory.

- I. Setting machine - Check feed dogs and elastic guide to be sure the machine is set to handle elastic.
 - A. Check feed dogs.
 1. Height should be 3/4 tooth.
 2. On differential machines:
 - a) Front and rear feed dogs should be level to start, set on "0" differential (straight feed).
 - b) Chaining feed dog should be 1/4 tooth lower than rear feed.
 3. On non-differential machines the feed dog should have a slight tilt (5-10°).
 4. On overlock machines three rows of feed dogs are needed to handle elastic.
 5. On machines with mechanical pullers:
 - a) If puller is over-pulling the feed dogs, consistent sizing CANNOT be maintained.
 - b) To accurately check stitch length setting, produce a sample while running your sewing machine at full RPM.
 - (1) With the puller raised from the work, set the stitch length at 1/2 stitch more than length desired.
 - c) With the puller lowered onto the work, set the stitch length as desired.

Example: When the specs call for 7 spi.
with puller raised - set for 7.5 spi.
with puller engaged - set for 7.0 spi.
 - B. Check elastic guide - In setting the guide, care must be taken that the elastic, under tension does not lift the front of the presser foot.

- II. Power source - check for correct connection.
 - A. 220 volt, single phase AC, nominal 2 low legs:
 - 1. Take voltage reading between 1st leg and ground _____ volts.
 - 2. Take voltage reading between 2nd leg and ground _____ volts.
 - 3. Take voltage reading between 1st and 2nd leg _____ volts.
 - 4. Check ground. The unit must be grounded to the existing power source ground.
 - B. 110 volt, single phase AC
 - 1. Take voltage reading at connection point _____ volts.
 - 2. Check ground. The unit must be grounded to the existing power source ground.
- III. Metering roller assembly - Check for proper installation.
 - A. Check the idle roller adjustment:
 - 1. Use the following test to be sure that the idle (small) roller is parallel with the driver roller.
 - 2. Cut a piece of writing paper 1/4" wide by 2" long to make a test strip.
 - 3. Open the idle roller and insert test strip on the left side. Release idle roller. Hold driver roller with thumb and pull up on test strip. Repeat for right side.
 - 4. The left and right tests should show the same tension. If they do not, adjust the idle roller to meet the driver roller squarely.
 - 5. After adjustment, check that the idle roller can spin freely when moved away from the driver roller.
 - B. Check the spring tension.
 - 1. Measure the length of the spring when the rollers are together.
 - 2. The length should be 7/8" with a tolerance of $\pm 1/8$ ".
 - C. Check the metering mechanism location.
 - 1. Viewed from directly overhead, measure distance from the rear of the driver roller to the front of the presser foot (nominal: one inch).
 - 2. The driver roller should be at least one inch in front of the presser foot to prevent the elastic from lifting the presser foot.

Sample EMX-3 Worksheet

Follows...

TRIMMASTER

EMX-3 Worksheet

Set-Up(1)	Step	Tension Setting (2)	Advance / Pull-Back Stitches(3)	Stitch Count (4)	Description
A	1				
	2				
	3				
	4				
	5				
B	1				
	2				
	3				
	4				
	5				
C	1				
	2				
	3				
	4				
	5				
> (5)	Speed adjustment:				

Notes:

- (1) - The EMX-3 can store three independent set-up's, A, B, and C.
- (2) - Enter a tension setting. The degree of gathering achieved by a particular tension setting depends on stitch length. See the instructions for the formula for tension setting.
 - Leave the setting at zero (0000) to indicate the previous step was the last step (if fewer than 5 steps are needed).
- (3) - Enter the duration, in units of sewing machine stitches, that the metering device should advance (fast- forward) or pull back before switching to the tension setting in this step.
 - The entry for step 1 controls the transition from the last step back to step 1.
- (4) - If stitch counting is desired, enter the number of stitches the device should stay at the indicated setting before advancing to the next step.
 - Set the stitch count to zero (0000) to indicate a knee switch (or other switch) will be used.
- (5) - Enter a percent, 0 to 9, that the metering device should slow down when the sewing machine is running slower than 1,200 RPM.